

4

3

2

1

E.W.O. 4501

PH1527-1 SHIPBOARD TEST RIG (TYPE XIV CROSSBAR FITTING)

DIMENSIONAL DATA
DIMENSIONS SHOWN IN INCHES AND [MILLIMETERS]
DIMENSIONS ARE REFERENCE ONLY

SPECIFICATIONS:

MATERIAL:
STEEL

TEST LOAD:
32,000 LBS.

FINISH:
PAINTED-YELLOW

WEIGHT:
66.7 KGS (147.0 LBS.)

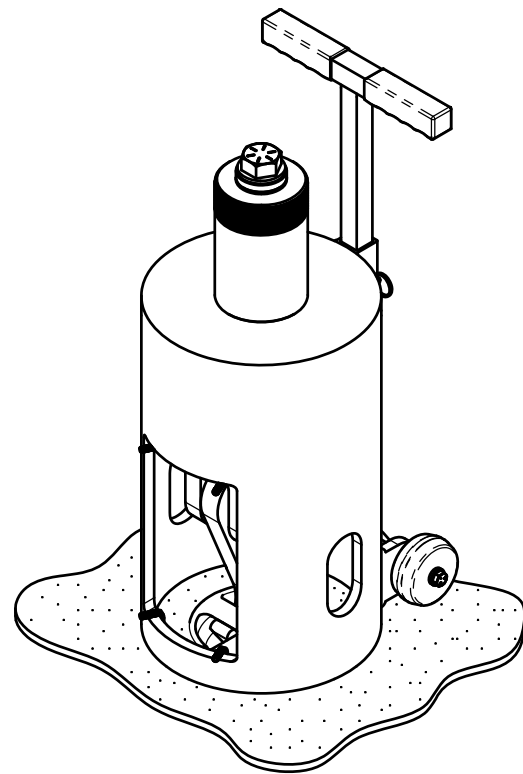

APPLICATION

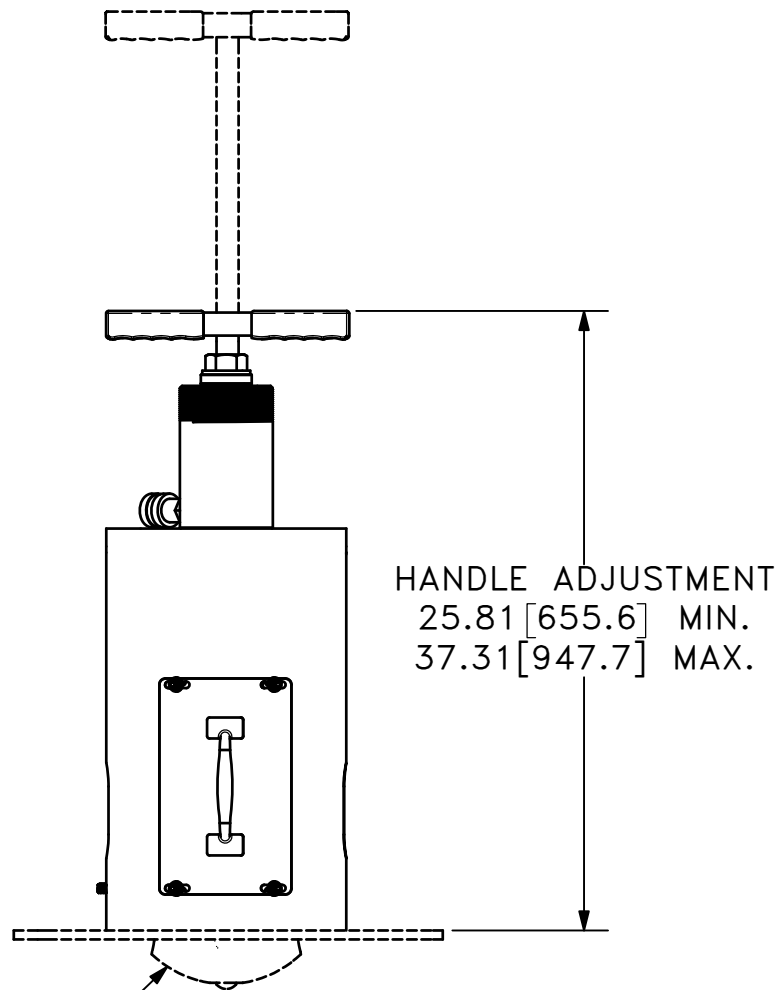

PH285 SOCKET
TYPE XIV CROSSBAR FITTING

PH1527-1 SHIPBOARD TEST RIG

Peck & Hale® PECK & HALE, L.L.C.
180 DIVISION AVENUE
W. SAYVILLE, NY 11796 USA
Cargo Securing Systems and Solutions

THIS DRAWING AND ANY PRINT MADE THEREFROM IS THE EXCLUSIVE PROPERTY OF PECK & HALE. IT MUST NOT BE TRACED NOR REPRODUCED IN ANY MANNER NOR SHALL IT BE SUBMITTED TO OUTSIDE PARTIES FOR EXAMINATION WITHOUT OUR WRITTEN CONSENT. IT SHALL BE USED ONLY AS A MEANS OF REFERENCE TO WORK DESIGNED OR FURNISHED BY US.

FSCM No: 94658	DRN: A. CRENNAN	5309	—
DATE: 9/8/2020	CHK: S. JEFFREY		
SIZE: B	SCALE: NONE	DWG. NO.	REV.

4

3

2

1